



# USER MANUAL





## **Introduction**

**Read the manual before actuating your heat pump!**

**NB! Changing any properties entered either by the manufacturer or the installer is strictly forbidden!**

- Prior to actuating the heat pump the existing central heating system must be filled with the prescribed heat-carrying medium.
- The heat pump must be always transported in vertical position. Only in case of need (e.g. during the transportation on stairs) it can be inclined for a short while.
- Heat pump cannot be actuated when the power supply is malfunctioning.
- Should the compressor phase sequence change, the compressor will engage in reverse and crash.

## **General requirements when using the heat pump**

### **Indoor unit**

1. Indoor unit should always remain accessible. No heavy items should be placed atop the housing and stepping on it is strictly forbidden.
2. The floor of the room, where the indoor unit is located, should be kept dry. Check that no water can drop to the housing from the ceiling.
3. Any works in the indoor unit room that can produce dust, are forbidden. Dust can interfere with switchboard functions.
4. No items or objects should be hung on the heat pump pipework.

### **Outdoor unit (evaporator, Icestick)**

1. Outdoor unit should not be surrounded by trees, hedges or any kind of wind barriers. Using a wire mesh screen is allowed.
2. No items or objects should be hung on the mesh screen surrounding the outdoor unit.
3. The area under the mesh screen and its surroundings must be kept free of leaves and other thrash.



**OCTOPUS** air-to-water heat pump is simply built and technically extremely reliable. Its components are basically the same as those of a typical refrigerator. A heat pump is maintenance-free and once installed, does not need additional adjustment. All necessary consultations and spares are provided by Santehsystems LLC. All adjustments (except room temperature settings) and maintenance can be undertaken only by Santehsystems LLC or its authorised personnel.

## **Product Safety Warranty**

We hereby attest that the given product manufactured and produced by: Octopus Energi AB, fully complies with safety regulations of the European Union. The construction of this product is in accordance with safety regulations adopted in EU member states. Its installation, maintenance and usage does not endanger the health of people, domestic animals or other property.

Product: heat pump type IS20 - IS81

**EU pertinent directives:**    **89/392 EWG**  
  **91/368 EWG**  
  **73/23 EWG**  
  **97/23/EG, Article 3.3**

**Proceeding from the above data, Octopus heat pumps have received the CE marking.**



**Inside module**

## Technology

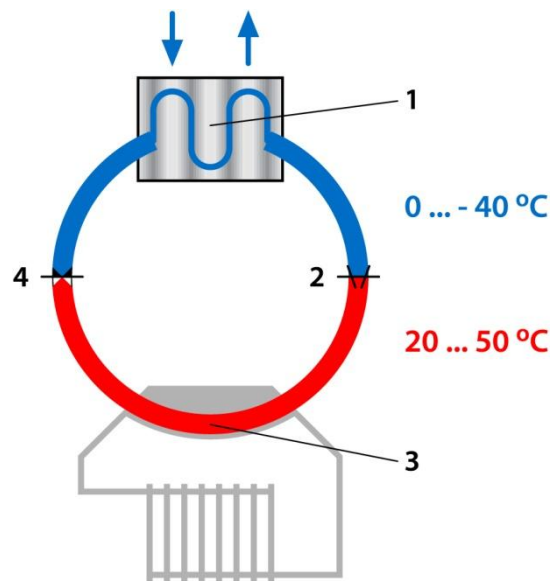

### 1. Heat-absorbing section

#### Low pressure

This part of the heat pump is called the evaporator. A refrigerant with a low temperature and boiling point runs thru the evaporator. The evaporator is heated up by the surroundings, which results in evaporating of the refrigerant.

### 2. Pressure-increasing section

#### High pressure

This part consists of a compressor. The compressor compresses the heated refrigerant, which leads to a pressure increase, resulting in significant rise of temperature and increase of the condensation point.

### 3. Heat emission section

#### High pressure

This section of the heat pump, transferring the heat to the house, is called the condenser. The refrigerant runs thru the condenser with a very high temperature and condensation point. In the condenser the refrigerant is cooled down by the heating system in the house, the heat has been transferred by for example the radiators, floor heating, etc, the refrigerant condensates.

### 4. Pressure-lowering section

#### Low pressure

This part consists of an expansion valve, which expands the cooled refrigerant. This lowers the pressure, resulting in substantial drop of temperature and boiling point of the refrigerant.

### Other

The heat absorbing part has no moving parts and does not demand any defrosting, enabling a quiet operation and a large-scale energy exchange.

At low temperature the heat pump works on auxiliary heat. Our heat pump is a closed circuit with the refrigerant Gasol (propane) that has a low boiling point, -42 degrees Celsius. The coefficient of performance (COP) varies between two and five, depending on the condition of the house, moisture in the air and the outdoor temperature.

## Components

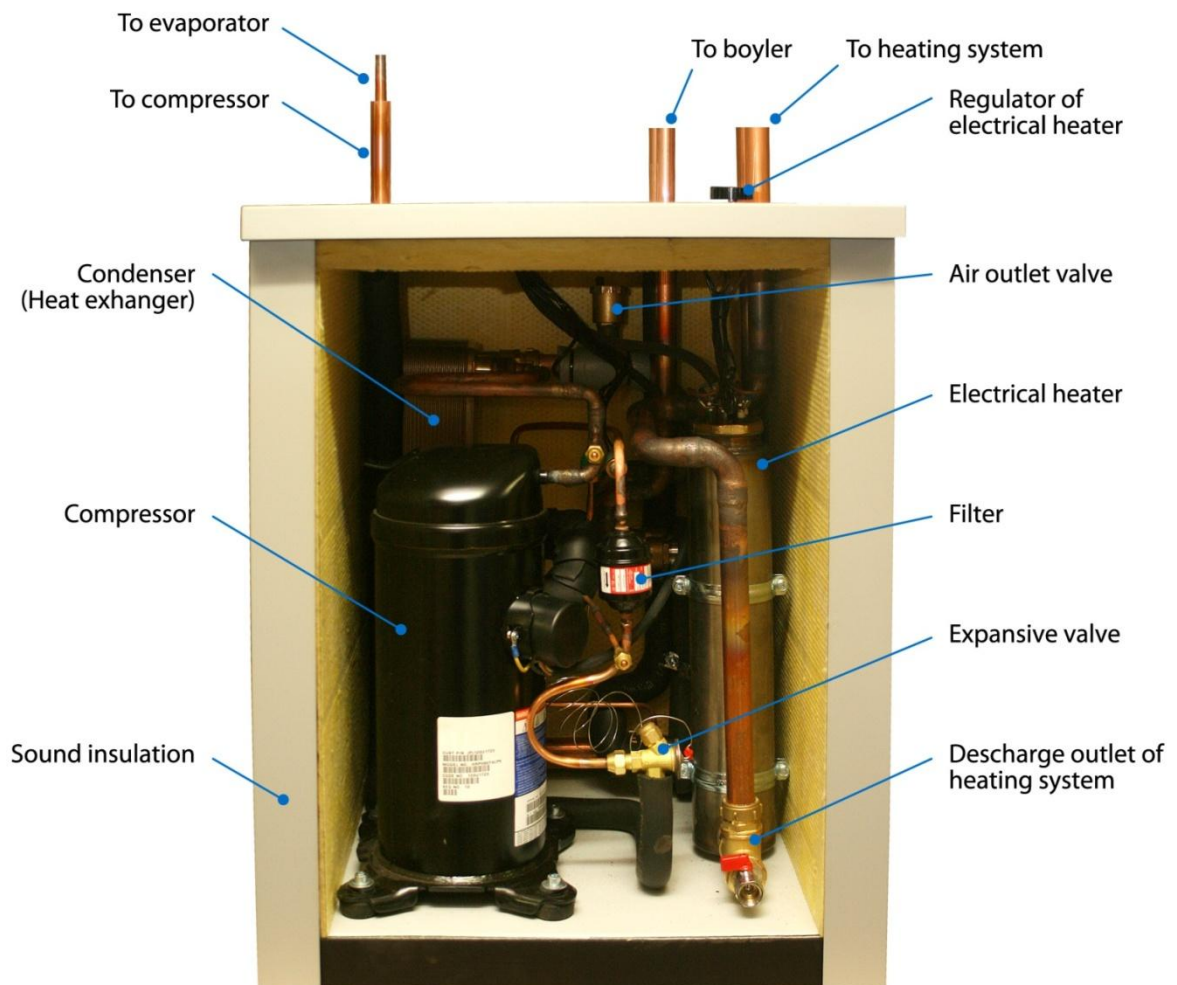



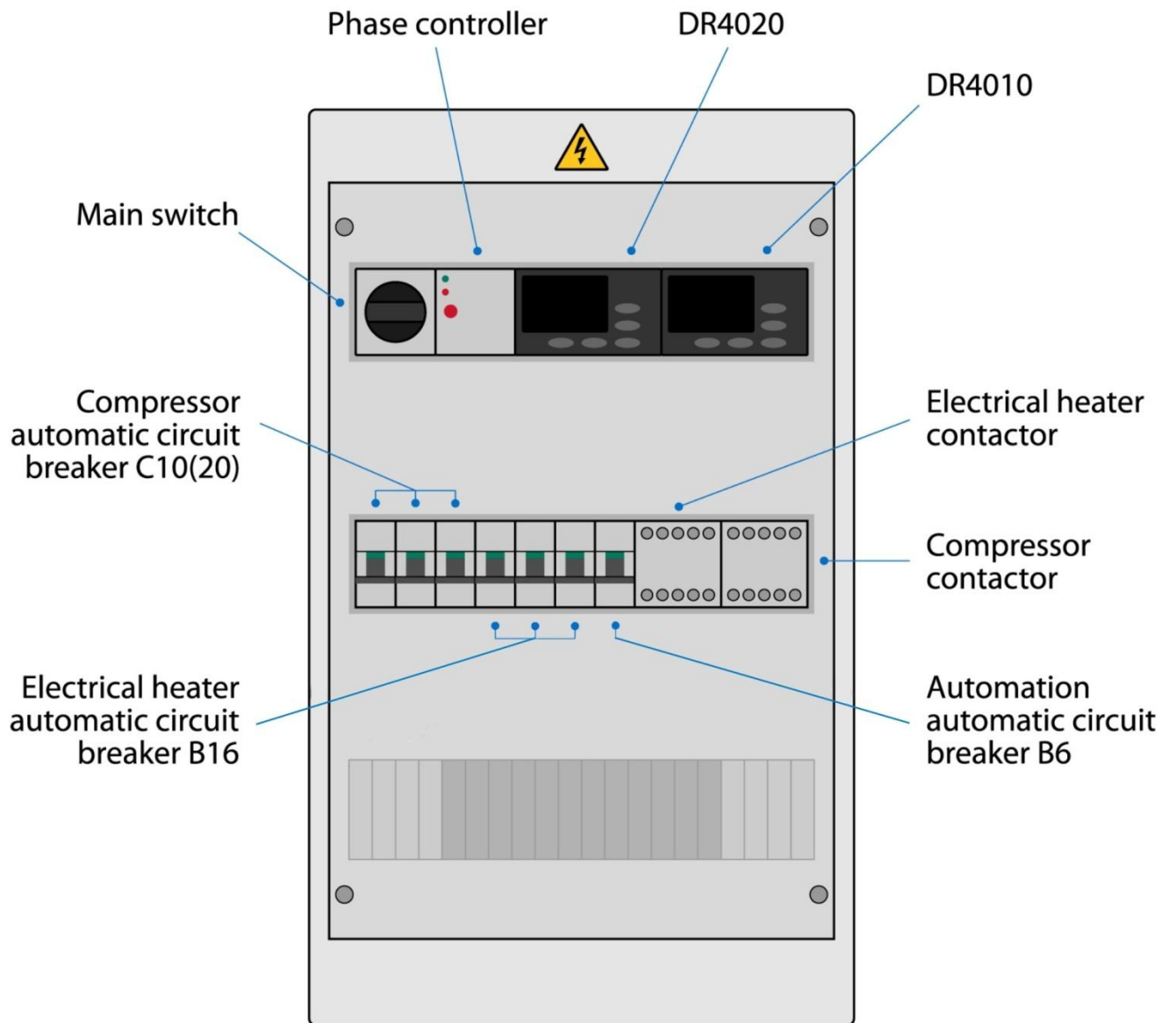

Heat pump steering panel

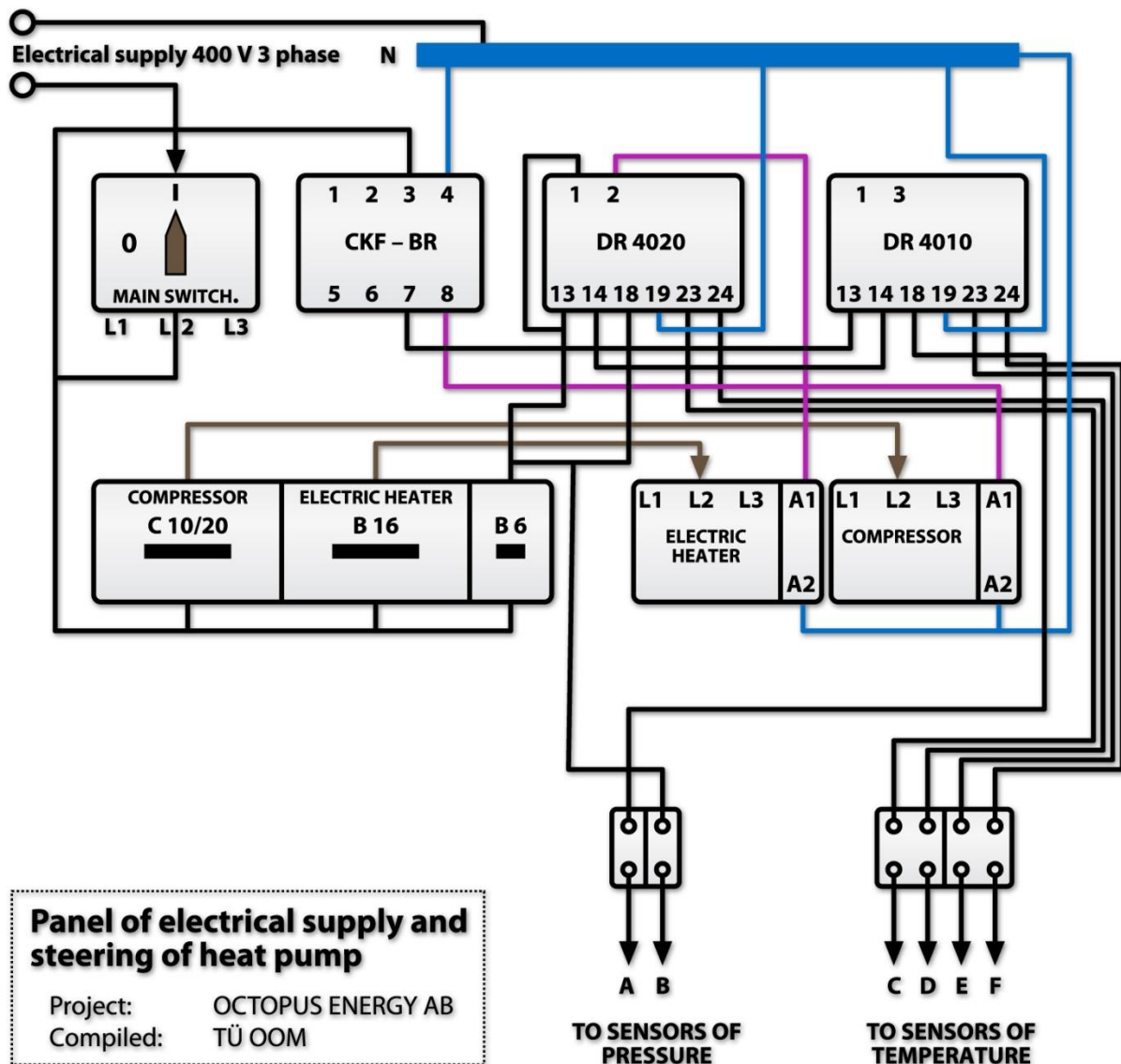

## Room Temperature Setting

The indoor heat pump steering panel includes two temperature clocks marked as DR4020 and DR4010. Room temperature can be regulated with the left-mounted DR4020 set. Its dial has three buttons – one with an arrow pointed upwards, one with an arrow pointed downward and one marked with the word ‘set’. To change the room temperature setting, follow the instructions shown on the scheme:

The delay period for stop or start of heat pump is 255 seconds.

**DR4010 shows the temperature of the water in the output of condenser and controls and protects the operating of heat pump. Changing any existing controller settings is forbidden, except by installer or other authorized personnel.**

# THE SETTING OF THE ROOM TEMPERATURE



## Keys



**UP**  
Increases values



**DOWN**  
Decreases values



**FNC**  
Opens Quick Star menu, ESC (exit function)



**SET**  
Confirms commands  
Activates functions



**AUX**  
Not in use

## Display and LEDs



**Process value (PV)**  
Existing room temperature

**Set Value (SV)**  
Set room temperature



**ALARM**  
ON if there is an alarm



**OUT 1**  
ON if the heat pump is activated















**OUT 2**  
ON if the el. heater is activated



**AUX**  
Not in use

## The setting of the room temperature

The following procedure is used to set the values of the 2 setpoints of the device: SET1 and SET2.

- 1   When the initial display is present, press the „set“ key.
- 2     The PV display shows SET 1 and the SV display shows the current setpoint value. The „UP“ and „DOWN“ keys can be used to change the setpoint value shown on the SV display. Press the „set“ key again to display SET 2.
- 3    The „UP“ and „DOWN“ keys can be used to change the setpoint value shown on the SV display. The set values of SET 1 and SET 2 must be equal.
- 4    When the „set“ or „fnc“ key is pressed, or the timeout has elapsed (15 sec), the new value appears and the initial display returns.
- 5  The initial display returned.





## Evaporator mounting and its connection to the building

### 1. Choosing the location

It is recommended to pick a location as windy and sunny as possible. It also should be located south of the main building. The evaporator should not be fenced in or surrounded by an hedge. The optimum distance from the building should be 2 to 20 meters or longer.

In case of an L-shaped building the evaporator should not be situated within its interior angle (cf. Fig. 1).

It is permitted to mount the evaporator to a building wall (cf. Photo 1) or its roof (cf. Photo 2).

### 2. Mounting the evaporator

The evaporator should be mounted to a concrete foundation measuring 1000 x 1000 x 400mm (cf. Fig. 2). The concrete foundation can be either poured or composed of properly secured blocks. A metal mounting can also be used, provided that it can withstand up to 400 kg load plus the wind interference. The evaporator should be secured to its foundation with four 10 x 100mm anchor bolts.

NB! Painting or other treatment of the evaporator surface is forbidden. It is permitted to fit it with a lightning source.

### 3. Connecting the evaporator with heat pump inside module

The evaporator is connected to the heat pump inside module by soft gas pipes made of copper.

**Using water pipes for this purpose is forbidden!**

1/2" pipes can be used for outgoing pipes and a 3/4" or 7/8" pipe to connect the evaporator with the compressor (cf. Fig. 3 and 4). The 3/4" pipe is also used in Octopus IS 61 as an additional loop\*.

The pipes should be placed into a 400...700 mm wide trench, as far from each other as possible.

In case if the expansion valve is adjacent to the evaporator, the gas pipes should not be isolated; they should be placed next to each other as close as possible.

\*There are two solutions to increase the efficiency of heat pump Octopus IS 61:

to use icestick with 14 sticks (standard icestick has 12) or to add the ground evaporator loop 30...60 m.

### 4. Shaping the pipes

A special tool should be used to shape the pipes. Minimum curvature radii should be as follows:

1/2" – 65 mm, 3/4" – 130 mm, 7/8" – 150 mm.

In case of smaller curves special elbows are mandatory.

Copper pipes should be joined with 30% hard soldering.

30% hard soldering is used to join copper pipe with a corrosion-proof metal.

### 5. Pipe lead-ins

The pipes should be isolated with a 9 mm thick heat and humidity-proof insulation. Isolated pipes will transit into the building via an 110 mm moisture resistant plastic conduit (cf. Fig. 5). In case if the expansion valve is adjacent to the evaporator, the underground pipes leading to the compressor should be insulated from one meter distance of their entry into the building on.

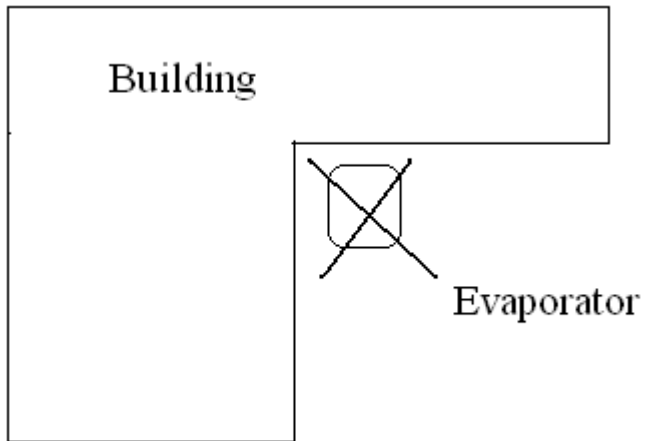

Fig. 1

Photo 1



Photo 2

### Evaporator foundation

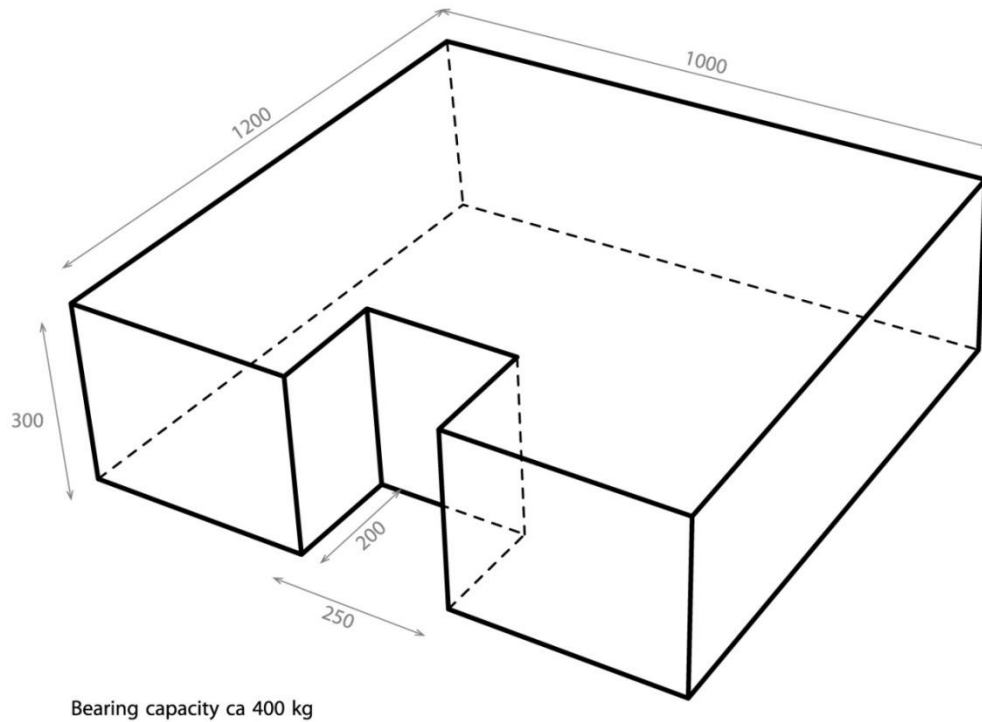

**Fig. 2**

The placement of tubes between the evaporator and the building

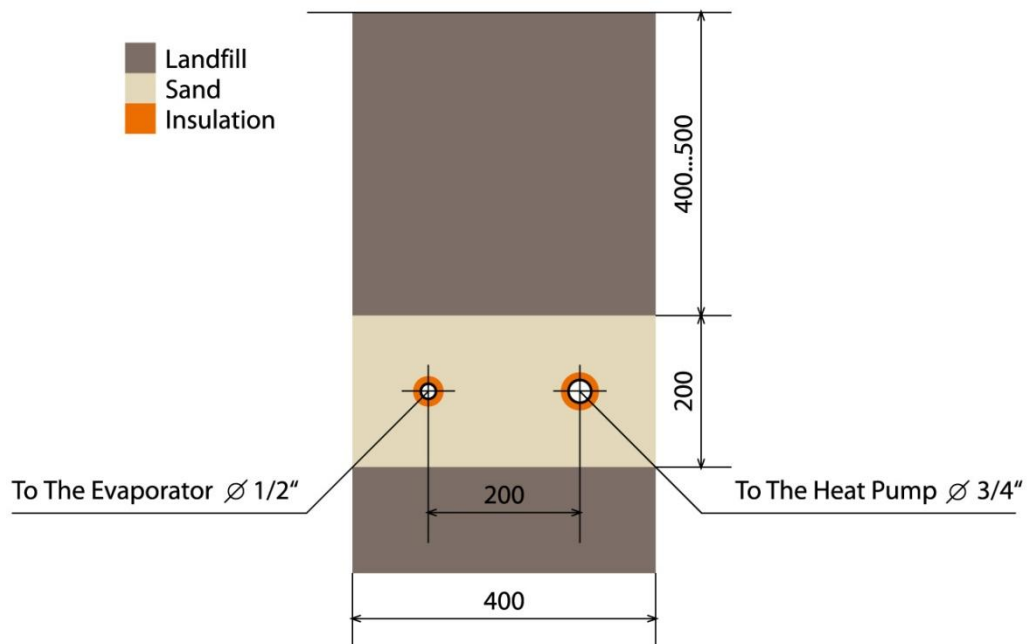

**Fig. 3**

### The placement of tubes between the evaporator and the building

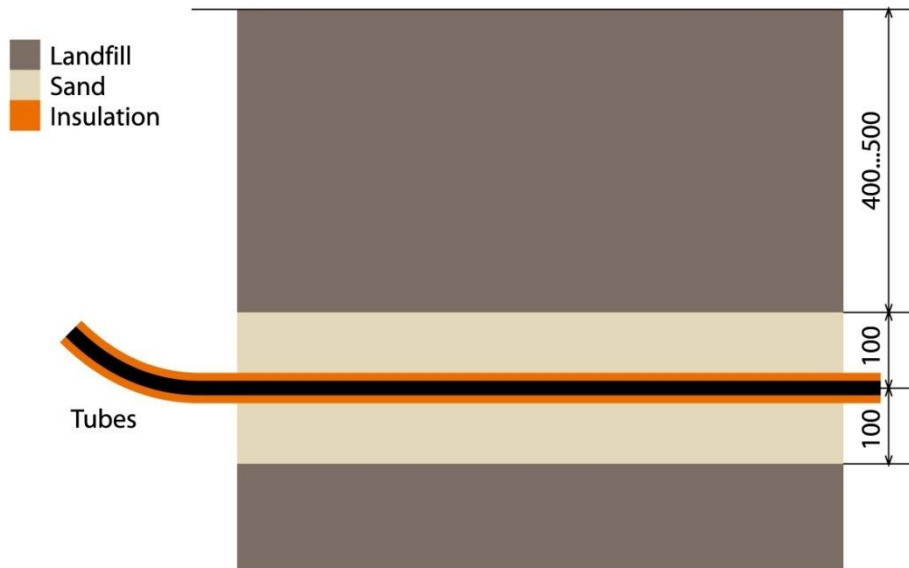

**Fig. 4**

### Input of the tubes

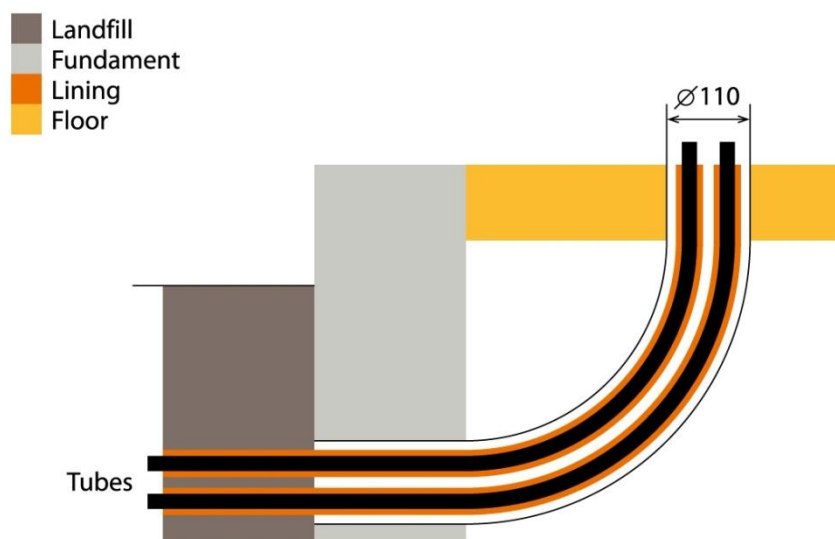

**Fig. 5**



## Technical data

Parameter, name	IS 28XP	IS 48	IS 61	IS 81
Evaporator				
number of sticks	8	12	12...14	2x12
weight, kg	65	97	97/107	2x97
dimensions, mm	800x840x2220	810x980x2220	810x980x2220	810x980x2220
Refrigerant	R-290	R-290	R-290	R-290
amount, kg		1	1	2
temperature boil/cond	-42/+64	-42/+64	-42/+64	-42/+64
Compressor, type	scroll	scroll	scroll	scroll
input, kW	1,8	3	3,7	5
voltage, V	220/380	380	380	380
steering voltage, V	220	220	220	220
level of noise, dB	30	45	45	45
Output capacity, m <sup>3</sup> /h	6,8	11,4	14,4	19,2
Pressure min/max, bar	1,5/23	1,5/23	1,5/23	1,5/23
Electrical heater				
effect, kW	3	6	6...9	9...12
voltage, V	220/380	380	380	380
Heating capacity, kW	10...15	12...20	15...25	20...30
Heating efficiency, kWh	...20 000	20 000...35 000	25 000...50 000	35 000...70 000
Max temperature, °C	50	50	50	50
Inside module, dimensions	605x580x820	605x580x820	605x580x820	605x580x820
weight, kg	80	105	110	115
Fuse, A (slow)	10	16	20	25





## Troubleshooting, possible maintenance failures and malfunctions

Description	Cause of trouble	Elimination
Rapid temperature increase of outgoing heating water	Clogged mud filter of the heating system	Clean the mud filter
	Insufficient circulation volume	Check the circulation pump of the heating system; replace if necessary
Evaporator does not freeze over or freezes partially	Insufficient circulation volume	Clean the mud filter. Check the circulation pump of the heating system; replace if necessary.
Irregular sound of the compressor	Several possible explanations	Inform the installer of your heat pump
Heat pump fails to increase the water temperature as intended	Excessive freezing of the evaporator (no light visible between the evaporator sticks)	Clean the sticks using some wooden tool
	Electrical heater is switched off	Switch the heater in
	Electrical heater does not work	Inform the installer of your heat pump
Heat pump fails to switch in	Phase sequence has been changed	Call an electrician
	Other reasons	Inform the installer of your heat pump
Heat pump fails to heat the rooms to the intended temperature	Temperature sensor failure	Inform the installer of your heat pump
	Building heat losses exceed the capacity of the given heat pump	Install an additional heating source or a more powerful heat pump model
	Insufficient capacity of the installed circulation pump	Install a more powerful circulation pump
E1 reading on the thermostate screen or temperature is floating on the thermostate screen	Temperature sensor failure	Inform the installer of your heat pump
Water temperature controller does not light up	Gas leak or excessive gas pressure	Inform the installer of your heat pump



### **Attention!**

Following the start of the system the temperature of the outgoing flow should be checked regularly. A rapid increase of the temperature can indicate that the mud collector is clogged. It is recommended to clean the collector 3-4 times within the first month after the launch. This measure effectively prevents damage to circulation pumps.

### **NB!**

Once the circuit breaker has tripped, you can reset it. If the circuit breaker trips when you switch it on again, do not try to reset it but instead contact your service company immediately. Note. In case of a blackout do not switch off your heat pump. It will restart automatically after the power supply has been restored.

After a power failure you should ascertain the quality of the power supply.

In case of any other troubles immediately contact your service company.

### **Warranty Agreement**

Santehsystems LLC provides its OCTOPUS heat pumps with a 2 (two) year warranty, which does not include equipment produced by other manufacturers with shorter warranty periods and details installed by the buyer of the pump. The given warranty is limited to the repair or exchange of the broken part (unit, assembly).

Santehsystems LLC assumes no responsibility for accidental or consequential damages.

A breach of warranty conditions results in termination of the above agreement.

Warranty repairs of the equipment can be undertaken only by Santehsystems LLC or its authorised personnel.

### **NB!**

**In case of additional electric supply-related works the previous phase sequence must be retained. Any changes may result in compressor damage.**

### **Warranty period**

1. Warranty period starts with the transfer of the heat pump to its Buyer.

2. A heat pump has a warranty of 2 years.

### **Termination of warranty**

The warranty will be terminated in following cases:

- the Buyer has tampered with any of the seals on the heat pump;
- the Buyer has exchanged or disabled, opened or dismantled any of the heat pump's assemblies or details (even temporarily);
- the Buyer has violated the pertinent rules of maintenance, including any changes in original adjustments;
- the Buyer has failed to provide his heat pump with adequate electric supply or has tampered with the electric supply scheme without prior consultation with the Vendor;
- the Buyer has changed the location of the heat pump or its details.

The above warranty does not include any failures or damage related to the inadequate quality of the water or any other liquid of the given heating system.

### **Note.**

Once the warranty has been terminated, all repairs of the heat pump must be paid for.

Any requests to the personnel that are not warranty-related (checks of the working of the heat pump, its resetting, maintenance or relocation) are chargeable.



**Warranty Coupon**

Heat pump ...../model/

S/N.....

Buyer.....

Installer .....

Data of sale .....

Seller's Representative signature